

Nine-Patch Quilt Pattern Quilted Wall Hanging

Finished Size 21" x 17" (Horz) or 17" x 21" (Vert)

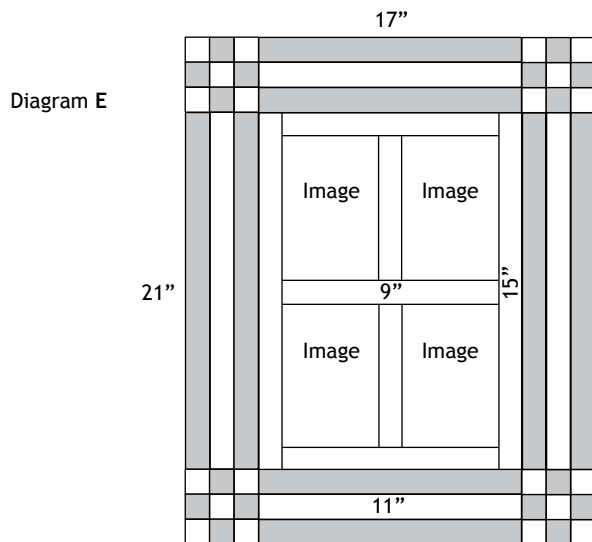

See our website
for a PDF File
image of this
pattern.

CARE INSTRUCTIONS:

Colorfast for hand washing:

Use cold water and mild (neutral PH) detergent;
an example of a neutral PH detergent would be Ivory, air dry.

Olde America Antiques American Quilt Blocks

To view more than 5,000 quilt blocks go to our web sites:

www.OldeAmericaAntiques.com

www.AmericanQuiltBlocks.com

Email: wonderland@montana.com • Tel: 406-587-0937

© 2006-2015 Olde America Antiques - All Rights Reserved



**American
Quilt
Blocks**

Nine-Patch Quilt Pattern Quilted Wall Hanging

Finished Size 21" x 17" (Horz) or 17" x 21" (Vert)



GENERAL INFORMATION:

Creator assumes the user has
basic sewing & quilting knowledge.

Adjust subcut strip lengths as
needed for personal measurements.

All seams are 1/4 inch.

FABRIC REQUIREMENTS:

1/4 Yard Light Fabric

1/3 Yard Dark Fabric

(includes binding)

2/3 Yard Backing Fabric

ADDITIONAL SUPPLIES NEEDED:

Sewing Machine in good working
order & new needle

Rotary cutting tools, mat, ruler,
cutter

Scissors

Straight Pins

Sewing Machine Thread

CUTTING DIRECTIONS:

LIGHT FABRIC: Cut 4 strips (selvage to selvage) 1 1/2" x 44"
 Subcut - 1 strip: 3 - 13" pieces (9-patch corners)
 1 strip: 2 - 6 1/2" and 3 - 9 1/2" pieces (sashing)
 1 strip: 2 - 15 1/2" and 1 - 11 1/2" pieces (borders)
 1 strip: 2 - 15 1/2" and 1 - 11 1/2" pieces
 (sashing and borders)

DARK FABRIC: Cut 4 strips (selvage to selvage) 1 1/2" x 44"
 Subcut - 1 strip: 3 - 13" pieces (9-patch corners)
 1 strip: 2 - 15 1/2" and 1 - 11 1/2" pieces (borders)
 1 strip: 2 - 15 1/2" and 1 - 11 1/2" pieces (borders)
 1 strip: 2 - 11 1/2" pieces (borders)

Cut 2 strips for 80" continuous binding
 (strip width is personal preference)

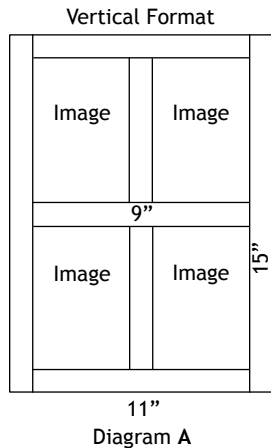

ASSEMBLY: (See Diagram A)

1. Carefully peel away the backing from your printed images. Trim the white border to 1/4" from the edge of the image on all 4 sides, this is your seam allowance.
2. Start with 2 images and add a 6 1/2" sashing strip between them. Repeat this with the other 2 images. Press with iron.
3. Take your 2 image pieces and add a 9 1/2" sashing piece between them, then add another 9 1/2" sashing piece on top and bottom of this unit. Next add a 15 1/2" sashing piece to the sides of the body of your wall quilt. Be sure to press with iron as you go.

PIECED 9-PATCH CORNERS FOR THE BORDER:

1. With your 13" strips of light and dark, sew one unit with dark-light-dark and another with light-dark-light as shown in diagram. **Press all seams to the dark fabric.** (See Diagram B)

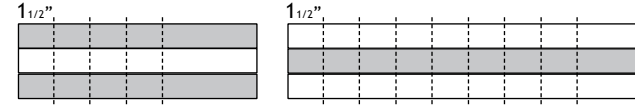

Diagram B

2. From the dark-light-dark unit, cut 4 - 1 1/2" pieces across the strips as shown in diagram. Do the same with the second unit (light-dark-light) except cut 8 pieces.
3. Sew your corner units (9 patches) as shown in  Diagram C, make 4 like this and press with iron.

Diagram C

ASSEMBLING THE BORDERS: (See Diagram D)

1. Take your 4 dark 15 1/2" pieces and 2 light 15 1/2" pieces and sew them together in 2 units, dark-light-dark, these are your side borders. Do the same with your 11 1/2" pieces. Make 2 units dark-light-dark for the top and bottom borders. **Press to the dark fabric.**
2. Sew the 2 15 1/2" units to the sides of the body of your wall quilt. Press with iron.
3. Sew one 9 patch corner block to each end of your 11 1/2" border units. These are your top and bottom borders, sew them to your wall quilt matching up the strips with the 9 patches. Press with iron. (See Diagram D)

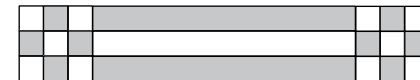

Diagram D

FINISHING YOUR WALL QUILT:

1. Sandwich your quilt with your choice of batt. Either hand quilt or machine quilt it in a pleasing fashion of your choice. Bind your wall quilt and you are finished! (See Diagram E on back)

